



Shower and wetroom solutions

ACO Sanitary Drainage

Product Catalogue



ACO offers shower drain solutions for a range of applications

The ACO ShowerDrain range just got even more versatile. From modular channels for public showers to solutions tailored for vinyl floors, we offer drainage innovation for every environment:

- **Modular 125** – extendable channels perfect for leisure facilities
- **ShowerDrain C** – boosted flow rate & easier cleaning
- **ShowerDrain B** – ideal for cost-effective installations
- **ShowerDrain E** – specialist solution for vinyl flooring
- **Point Drainage** - choices for a range of flow rates

Whether it's for care homes, wetrooms, or sports facilities—ACO delivers performance, practicality, and choice.

ACO Modular 125

The commercial wetroom channel

Page 26

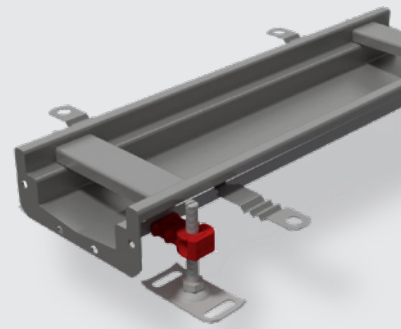

ACO ShowerDrain C

The practical channel

Page 20



ACO ShowerDrain B

The project solution

Page 28



ACO ShowerDrain E

The flexible channel

Page 24



Point drainage

Various floor drains for every application

Page 32



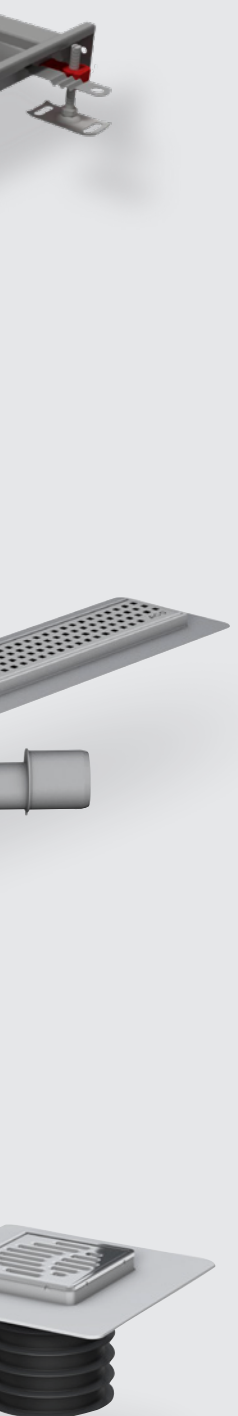

1	ACO ShowerDrain	6
2	Technical information	
	Gradient and drainage capacity	16
	The material stainless steel in shower areas	17
3	Product overview: Shower channels	
	ACO ShowerDrain C	20
	ACO ShowerDrain E	24
	ACO Modular 125	26
	ACO ShowerDrain B	28
4	Product overview: Point drainage	
	ACO Shower Gully System for flexible sheet flooring	32
	ACO Shower Gully System for tiled floors	34
	ACO Passino	36

ACO. we care for water

ACO is a Water-Tech company that protects water. Building on our global drainage expertise that protects people from water, we increasingly see our mission as also protecting water from people.

With the ACO WaterCycle, ACO provides systems that collect and channel, clean, retain and ultimately reuse water. In this way, ACO contributes to the preservation of clean groundwater as a vital resource, and makes a contribution to tomorrow's world. In its Agenda 2030, the UN global community set the improvement of water quality as one of 17 sustainable development goals.

Intelligent drainage systems from ACO increasingly use smart technology to ensure that rainwater and wastewater are drained, or temporarily stored. With innovative separation and filter technology, we prevent water contamination by pollutants such as fat and grease, fuels, heavy metals and microplastics.

Today, ACO goes one step further: we accept the challenge of reusing water, and thus establishing a resource-saving cycle. For all products and systems, ACO attaches great importance to durability, reusability and a low carbon footprint. The pursuit of sustainability is an ongoing process that we strive to meet every day.

The ACO Group is a global family business that is one of the world market leaders in the Water-Tech segment. Founded in Schleswig-Holstein in 1946, it operates as a transnational network in over 50 countries. Worldwide, ACO is characterised by a high level of decentralised ownership, and explicit regional market proximity.

www.aco.com



Managing Directors ACO Group
Iver and Hans-Julius Ahlmann



Headquarters of the ACO Group
in Rendsburg/Büdelndorf



5,200

employees in more than 47 countries (Europe, North and South America, Asia, Australia, Africa)

1 Billion

Euro Sales in 2021

37

production sites in 18 countries



ACO Academy
for practical training

ACO ShowerDrain

Elegant products for each specification



Hotel, wellness and spa

When it comes to leisure centres and swimming pools, drainage isn't just a detail—it's critical. ACO Modular 125 channels give you:

- The flexibility to design custom shower drainage systems
- Systems to handle the flow rate you require

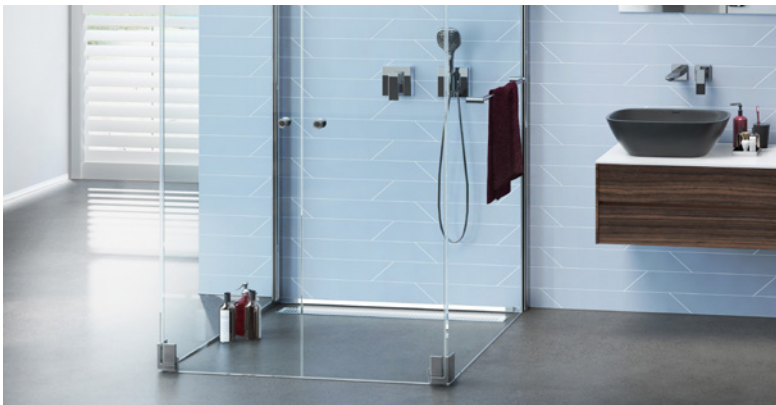

Residential and public buildings

Due to the variety of ACO ShowerDrains, ACO has solutions for virtually all structural challenges required. From fire protection and various installation heights to a channel with a vertical outlet.

- Fire protection
- Various installation heights
- Modular systems



Health and care

To improve hygiene together with a superior finish, ACO offers electro polished channels and gratings.

- Guarantees maximum safety and hygiene
- Quick and easy cleaning
- Low maintenance requirements



Barrier-free design

ACO ShowerDrain - a design statement. Whether against the wall, in the centre of the shower. Let your imagination run wild.

- Variety of design options
- Safe and easy to install
- Easy handling

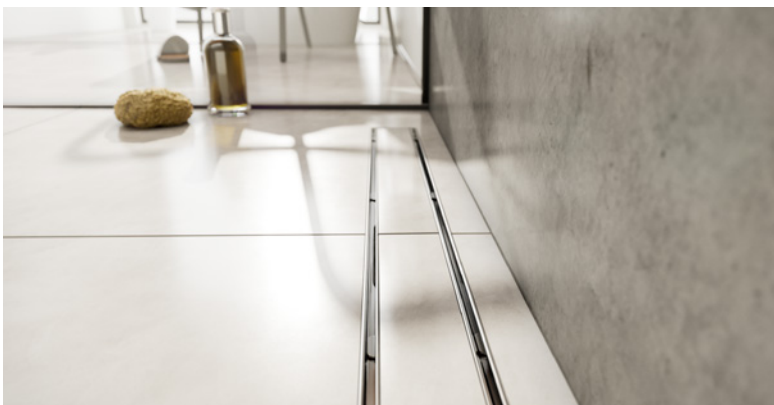

Hygiene benefits and durability

Manufactured to an extremely high standard, ACO's range of channels and gratings is perfect in relation to hygiene, operational safety and durability regarding product life.

- High-alloy stainless steel
- Completely pre-assembled or modular systems
- Plain welding seams for easy cleaning



Design

There is a wide range of styles to choose from, so you never need to compromise performance for design. For added peace of mind, customers also get access to our sales team who provide expert advice to specifiers and installers, and when required, support your design of communal showers from scratch.

- Customized solution available
- High performance due to additional drainage gullies
- Drainage solutions from scratch

ACO ShowerDrain C

Powerful, robust, easy to clean!

ACO ShowerDrain C is the practical channel from ACO Building Drainage and stands for modern design and perfect functionality. The basis is the high-quality stainless steel used to manufacture the shower channel itself, the gully and the design grate. The shower channel, which is developed and produced in Germany, underwent a thorough model update. The new production process of the drain body, also called hydroforming, enables pipe forming into complex three-dimensional shapes. The hydroformed drain body is now characteristic.

In order to increase the already considerable drainage performance of ShowerDrain C, the gully has been reshaped to increase the flow rate and the large smooth radii enables easier cleaning. As before, the drain gully is firmly welded to the channel and guarantees a permanent seal.

- ACO ShowerDrain C
- High drainage capacity
- Factory-welded hydro-shaped gully, guarantees permanent tightness
- Removable foul air trap for optimal cleaning
- Free access to the pipe for optimal cleaning
- Available with wall flange or surrounding flange

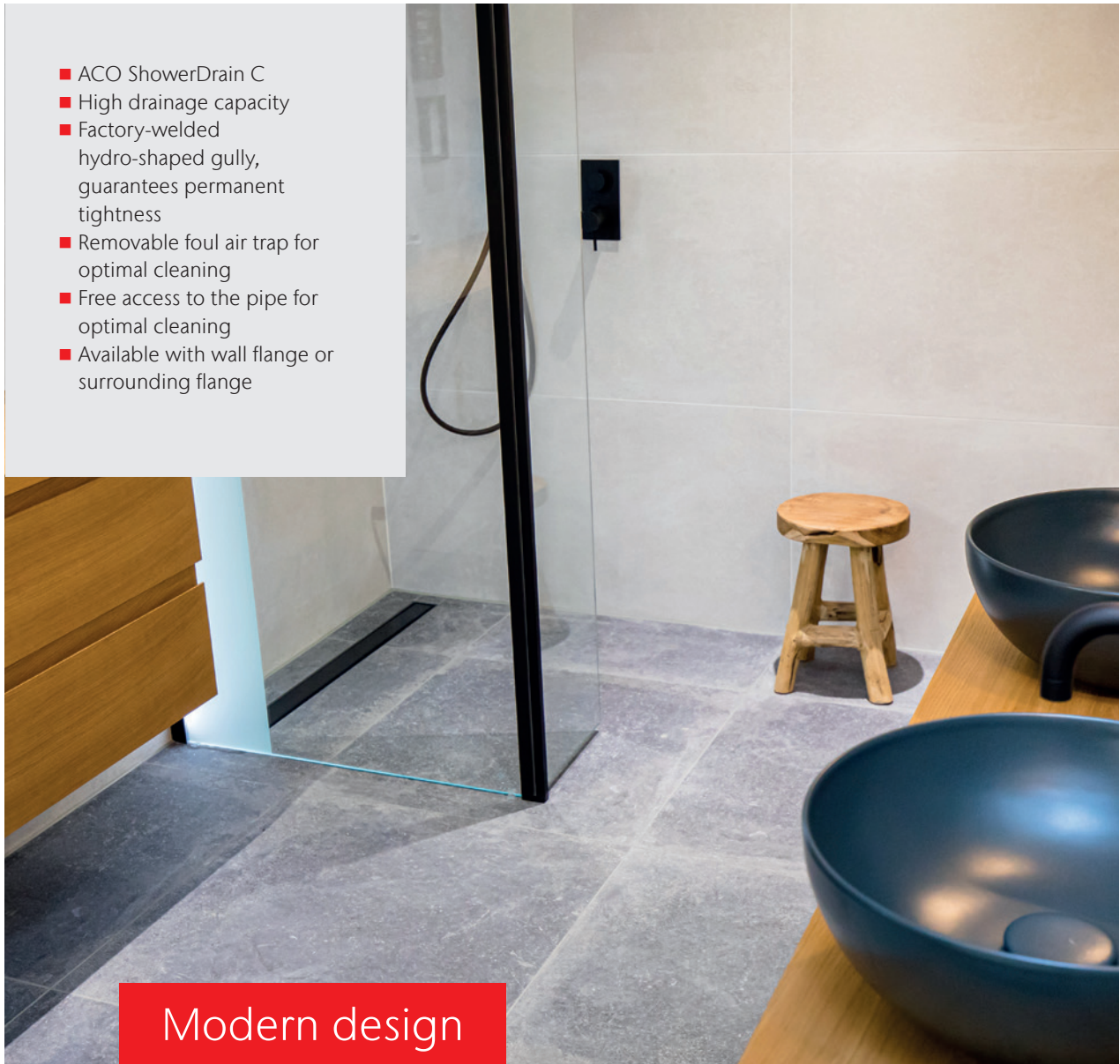

Modern design

and enhanced functionality



With the new drain gully, the channel achieves a very high drainage capacity despite its low installation height and narrow shape: up to 0.91 l/s (tested in accordance to EN 1253-1). The ACO ShowerDrain C is delivered completely pre-assembled, the channel and drain gully are guaranteed to be tightly welded. The material hardness reduces scratches and signs of use and is resistant to common cleaning agents. The high-quality appearance of the surface is convincing with low dirt adhesion and high ease of cleaning.



Long-lasting satisfaction is not only ensured by drainage performance and durable surfaces. It is often the small details, that make unpopular, but necessary cleaning tasks easier. The new foul air trap has two outer tabs that allow it to be removed without reaching into the trap, making cleaning more hygienic.

Once the foul air trap is removed, it can be easily disassembled into two parts, cleaned and reassembled. In addition, you have full access to the pipe for any necessary maintenance work. For special areas of use, e.g. hotels with seasonal operation, the shower channel can be retrofitted with the ACO EasyStop. The ACO EasyStop has a membrane insert that prevents the water seal in the odour trap from drying out.

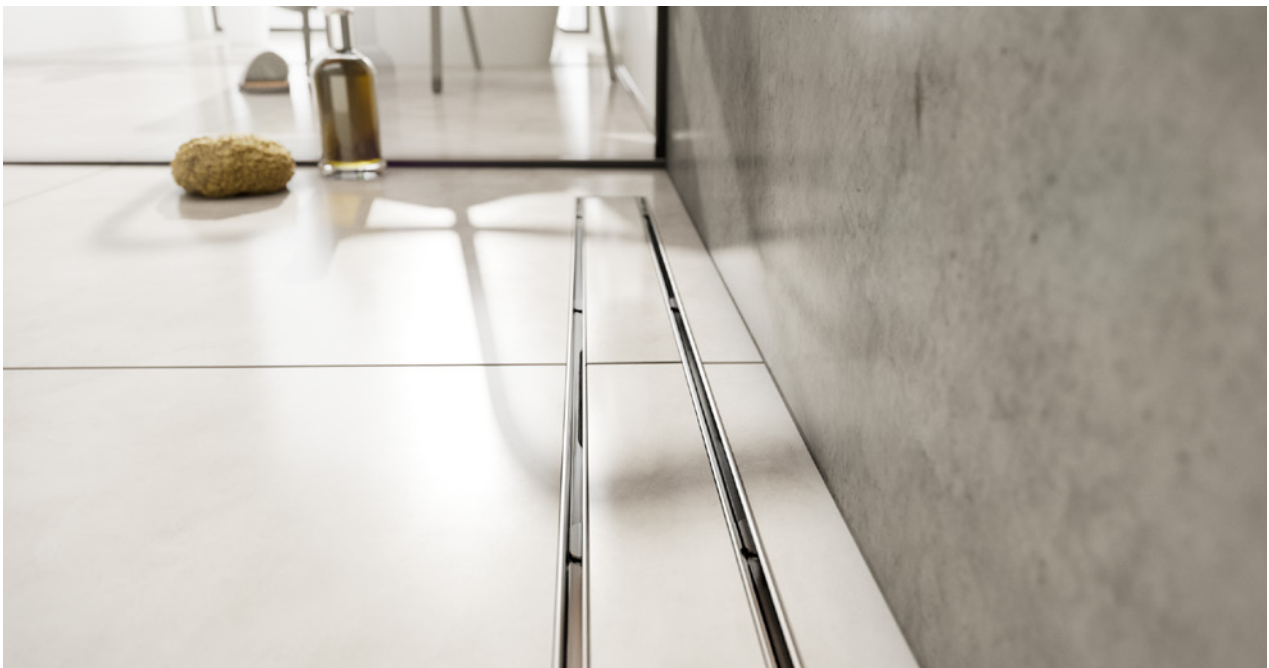

ACO ShowerDrain E

Everything is made simple by just turning!

The ACO ShowerDrain E is equipped with 360° rotatable gully body. With channel options that can be used for both vinyl and tiled floors it provide a very flexible solution for your wetroom.

Round shapes and flat surfaces ensure both a harmonious design and easy cleaning. The surface is also particularly resistant to cleaning agents. The odour trap allows free pipe access and thus easy cleaning.



ACO ShowerDrain E

- Option for secondary drainage
- Superior finish due to electro-polished channels and gratings
- Flexible for any installation situation
- Gully body can be rotated through 360°

Enormous flexibility

for every installation situation!

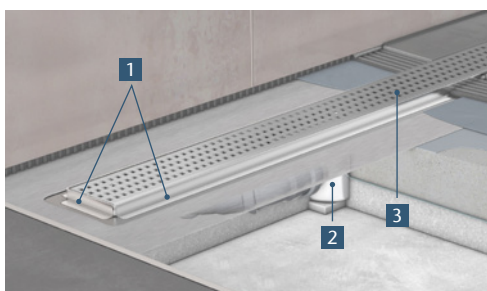

- 1 Durable, slim profile fully welded stainless steel
- 2 Rotatable outlet
- 3 Attractive finished stainless steel grating options

Modular system for every requirement

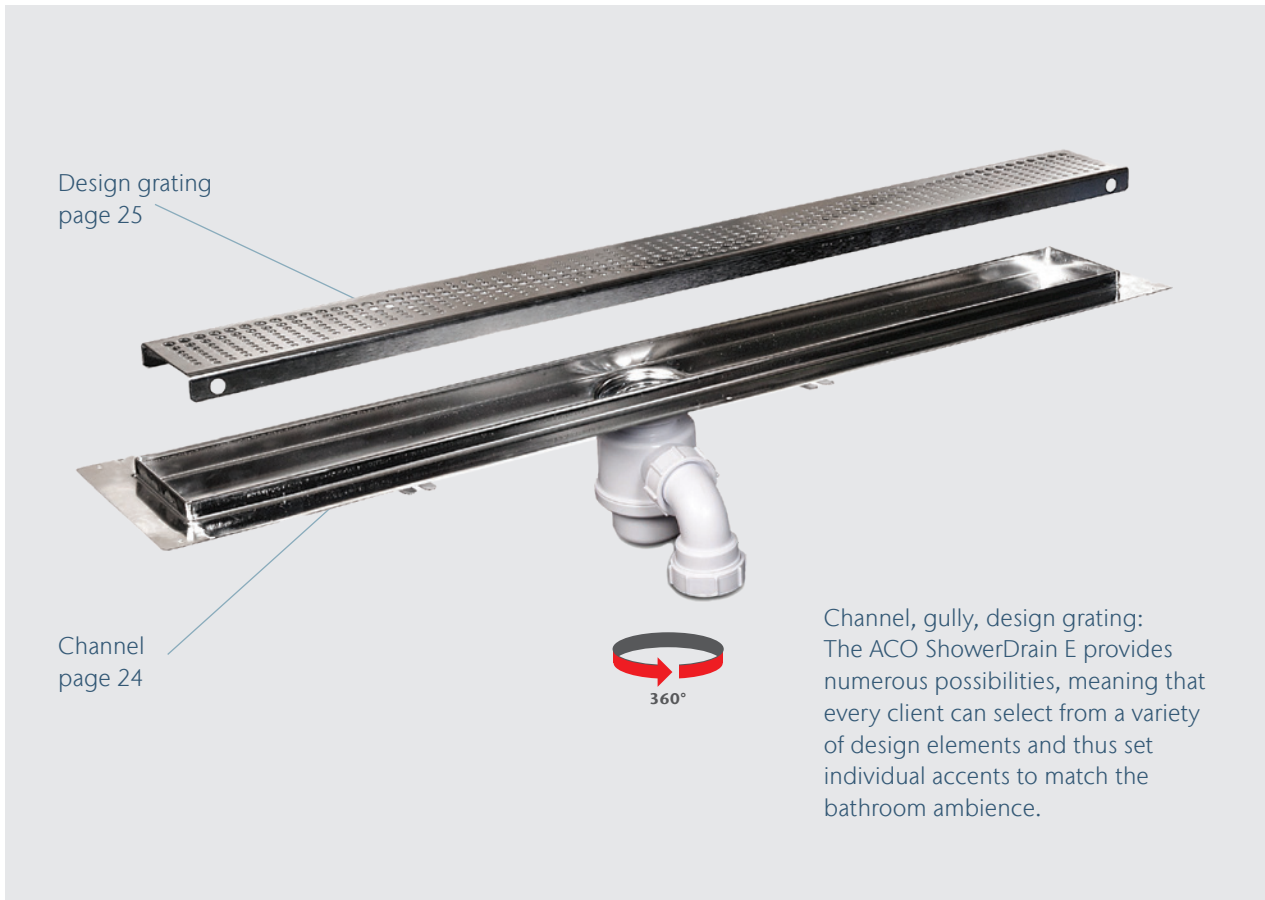

Channel, gully, design grating: The ACO ShowerDrain E provides numerous possibilities, meaning that every client can select from a variety of design elements and thus set individual accents to match the bathroom ambience.



◀ The challenge of installation heights comes up again and again, not only in renovation. ACO ShowerDrain E offers flexible solutions: Installation heights of 56 - 140 mm UFL (unfinished floor level) can be realized. Due to the choice of two drain bodies, the installation height can vary by 84 mm, which eases installation significantly.



◀ The ACO ShowerDrain E can be flexibly aligned through 360 degrees according to the course of the drainage pipe. Screwed in the middle, the gully body is therefore a secure, force-locked connection that holds the gully securely in position after installation.

ACO Modular 125

Setting individual accents

When it comes to leisure centres, spas, and swimming pools, drainage isn't just a detail—it's critical. ACO Modular 125 channels give you the flexibility to design custom shower drainage systems that rise to the challenge.

Whether you're managing multiple showers or high foot traffic, ACO delivers tailored solutions that meet the demands of high flow rates, chlorine resistance, and barefoot safety. Built for performance, engineered for safety—ACO ensures your shower drainage is as reliable as it is effective.

The 125mm wide, modular channel system provides a flexible off the shelf solution with a wide range of channel options, level or sloping inverts, corner and branch units and a variety of outlets.

All our Modular channels are fully pickle passivated to restore its corrosion resistance and optimum durability.

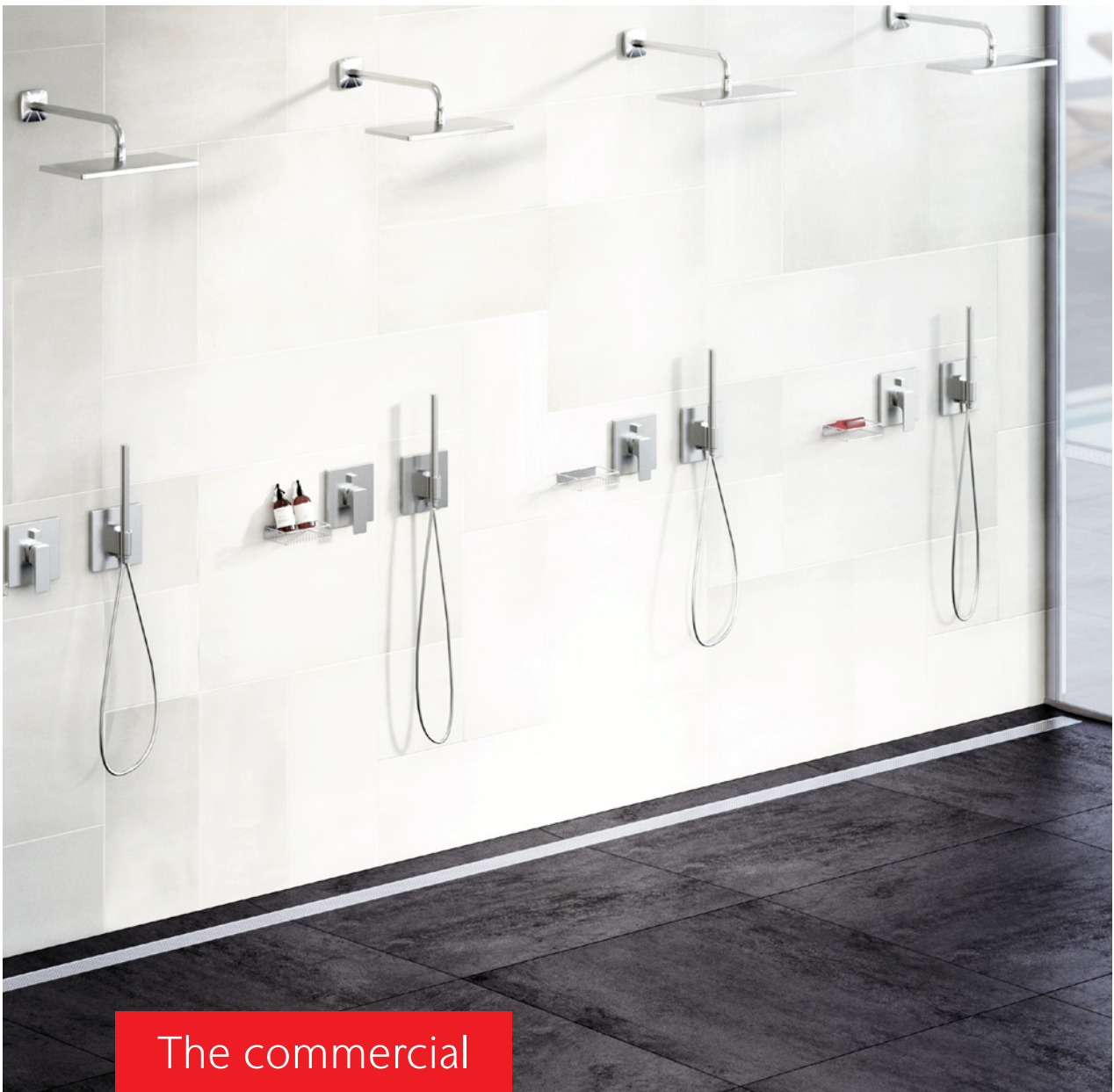

The commercial
wetroom channel

ACO Modular 125 at a glance

The flexible solution to meet your project needs

When you require a longer run of shower channels than standard single channels can provide, Modular is an ideal solution. With a range of channel lengths and inverts and a selection of drainage outlets our system can be designed to handle the flow rates you require within the shower area.

Please contact abdtechnical@aco.co.uk to discuss your needs



Flexible selection of channel gullies

The ACO Modular 125 range has a selection of gullies that are compatible that can handle flow rates up to 5 litres/sec. This means your shower system can be configured to handle the flow rate you require based on the number of showers and the volume water they produce. This means Modular is an ideal solution for shower systems in changing rooms and leisure centre shower areas.



2





Technical

Information

ACO Sanitary drainage

ACO offers various sanitary drainage systems. Our UK range includes ACO ShowerDrain channels and sanitary gullies with a range of grating designs available to suit your style.

New in our selection is the upgraded ACO ShowerDrain C and the ShowerDrain B offering a range of project options.

For projects needing bespoke lengths of channels we have our Modular 125 channels that can be configured to meet your specific requirements. For projects needing a wetroom solution for a vinyl/flexible floor our ShowerDrain E is ideal. ACO has the right solution for each application, from high-quality commercial wetrooms, hotels, spa, sports facilities to private bathrooms and supported living environments.

Gradient and drainage capacity

Conventional point gullies require a four-sided gradient in the tiling. By comparison line drainage enables a one-sided gradient. This makes use of large-format tiles significantly easier. A large gradient supports the drainage performance. A small gradient offers more slip resistance and is more wheelchair compatible. In practice gradients between 1.5 % and 2 % have proven successful. For example on a 2% gradient if 5mm water back flows above the grating during showering, the water will reach approximately 250mm into the room (see illustration below).

EN 1253-1 defines flow values for floor gullies and channels with foul air trap. Accordingly, a minimum value of 0.4 l/s is required for a shower area. This measured value must be achieved with a backflow of 20mm above the grating.

If no standing water is wanted during showering, the flow capacity of the shower fitting must be noted. contact ACO for advice on flow rates you need to manage in your shower installation area..

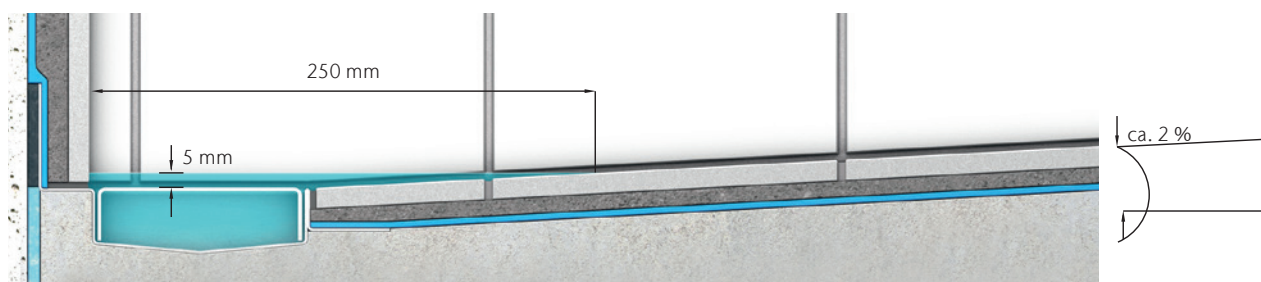

Water seal when mounting the shower channel on the wall



ACO ShowerDrain E+
Flow rate 0.4l/s (EN 1253-1)



ACO ShowerDrain C
Flow rate 0,91 l/s (EN 1253-1)

With other channel types, the drainage value can be increased by using several gullies.

The material stainless steel in shower areas

There are several good reasons for using stainless steel in sanitary engineering applications. Thanks to its smooth, hard surface, it does not need any protective layers made from either organic or inorganic materials. Stainless steel is also able to tolerate cleaning and disinfecting agents, even at high temperatures. The material does not become statically charged, a property that stops it from attracting dust particles and, as a result, bacteria. After coming into contact with hot water, its surface dries more quickly than other materials (particularly non-metal ones).

As such, there is no need to rub it dry – something that should be avoided anyway because of the risk of secondary infection. All ACO shower channels are fully pre assembled, which means that all the individual components are firmly connected. This guarantees that the shower channel is completely watertight. The ShowerDrain E product range also features a surface that has been electro-polished: in this process, any surface irregularities are removed by a passivating process to the point where a highly reflective surface is produced.



3



Product overview

Shower channels

ACO ShowerDrain C

The practical channel



20

ACO ShowerDrain E

The flexible channel



24

ACO Modular 125

The powerful communal shower channel



26

ACO ShowerDrain B

The project channel



28

ACO ShowerDrain C

Product benefits

- High drainage capacity
- Factory-welded hydro-shaped gully, guarantees permanent tightness
- Removable foul air trap for optimal cleaning
- Free access to the pipe for optimal cleaning

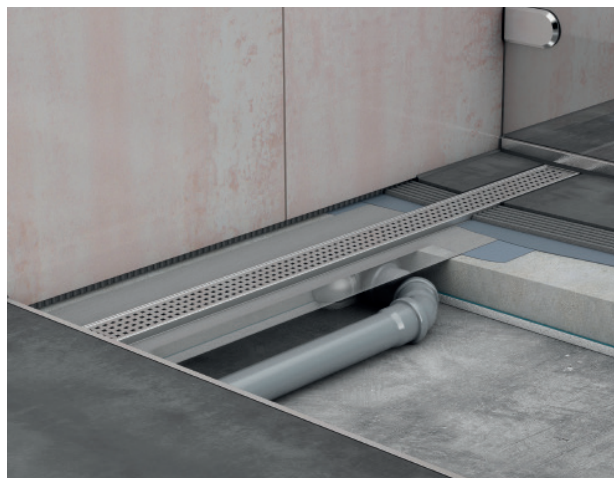

Product information

- Material: Stainless steel
- Load class: K3
- Internal channel width: 64mm
- Flow rate:
 - Gully with water trap 50mm (EN 1253-1)
 - 0,72 l/s with 10 mm built up
 - 0,91 l/s with 20 mm built up
- Outlet: Suitable for all push-fit pipe outlet systems
- Outlet version: ND 40/ND 50
- Foul air trap: 2-part, removable
- Type of flange: surrounding flange, wall flange
- Channel body: Pickle passivated
- Mounting: Ready for installation
- Sound protection (as standard)
- Installation height is between 80 and 128mm
- Height adjustability: 48mm respectively 74mm using mounting brackets (to be ordered as an accessory see P23)
- Grating variants: Stainless steel design gratings, tileable cover



Gully WS50







WS50



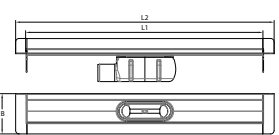

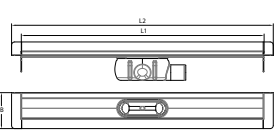
Order data, design gratings

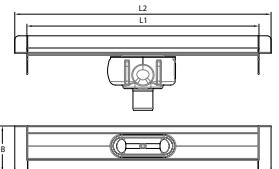
Product	Dimensioned drawing	Description	Dimensions			Part no.
			L1 [mm]	L2 [mm]	B [mm]	
Gully WS50, surrounding flange, outlet horizontal/central						
		<ul style="list-style-type: none"> ■ Water seal: 50 mm ■ ND 50 (EN 1253-1) ■ Installation height (UFL): 80-128mm (frame height 12mm) 	585	645	130	3005543
			685	745	130	2131385
			785	845	130	2131386
			885	945	130	2131387
			985	1045	130	2131388
			1085	1145	130	2131389
			1185	1245	130	2131390
Gully WS50, surrounding flange, outlet horizontal/lateral						
		<ul style="list-style-type: none"> ■ Water seal: 50 mm ■ ND 50 (EN 1253-1) ■ Installation height (UFL): 80-128mm (frame height 12mm) 	585	645	130	2131534
			685	745	130	2131535
			785	845	130	2131536
			885	945	130	2131537
			985	1045	130	2131538
			1085	1145	130	2131539
			1185	1245	130	2131540
Gully WS50, surrounding flange, outlet vertical						
		<ul style="list-style-type: none"> ■ Water seal: 50 mm ■ ND 50 (EN 1253-1) ■ Installation height (UFL): 80-128mm (frame height 12mm) 	585	645	130	2131576
			685	745	130	2131577
			785	845	130	2131578
			885	945	130	2131579
			985	1045	130	2131429
			1085	1145	130	2131430
			1185	1245	130	2131431
Gully WS50, wall flange outlet horizontal/central						
		<ul style="list-style-type: none"> ■ Water seal: 50 mm ■ ND 50 (EN 1253-1) ■ Installation height (UFL): 80-128mm (frame height 12mm) 	585	645	122	2131391
			685	745	122	2131392
			785	845	122	2131393
			885	945	122	2131394
			985	1045	122	2131395
			1085	1145	122	2131396
			1185	1245	122	2131397





Order data, shower channel

Product	Dimensioned drawing	Description	Dimensions			Part no.
			L1 [mm]	L2 [mm]	B [mm]	
Gully W550, wall flange, outlet horizontal/lateral						
		<ul style="list-style-type: none"> ■ Outlet on the left side ■ Water seal: 50mm ■ ND 50 (EN 1253-1) ■ Installation height (UFL): 80-128mm (frame height 12mm) 	585	645	122	2131548
			685	745	122	2131550
			785	845	122	2131552
			885	945	122	2131554
			985	1045	122	2131556
			1085	1145	122	2131558
		<ul style="list-style-type: none"> ■ Outlet on the right side ■ Water seal: 50mm ■ ND 50 (EN 1253-1) ■ Installation height (UFL): 80-128mm (frame height 12mm) 	585	645	122	2131549
			685	745	122	2131551
			785	845	122	2131553
			885	945	122	2131555
			985	1045	122	2131557
			1085	1145	122	2131559
		<ul style="list-style-type: none"> ■ Water seal: 50mm ■ ND 50 (EN 1253-1) ■ Installation height (UFL): 80-128mm (frame height 12mm) 	585	645	122	2131520
			685	745	122	2131521
			785	845	122	2131522
			885	945	122	2131523
			985	1045	122	2131524
			1085	1145	122	2131525
			1185	1245	122	2131526

Order data, design gratings

Products	Design	Part no.						
		585 mm	685 mm	785 mm	885 mm	985 mm	1085 mm	1185 mm
	Wave	2131440	2092974	2092975	2092976	2092977	2131441	2092979
	Square	2131442	2092980	2092981	2092982	2092983	2131443	2092985
	Tile	2131447	2079082	2079083	2079084	2079085	2131448	2092990
	Slot	2131444	2079078	2079079	2079080	2079081	2131445	2131446

Order data, accessories

Product	Name	Description	Part no.
	ACO EasyStop ND 40	<ul style="list-style-type: none"> ■ Prevents drying out of the water in the foul air trap ■ Material: plastic with membrane and sealing lip 	2025351
	ACO EasyStop ND 50	<ul style="list-style-type: none"> ■ Applicable for ACO ShowerDrain C 	2025352
	Replacement foul air trap	<ul style="list-style-type: none"> ■ WS 50 ■ Applicable for ACO ShowerDrain C 	2079069
	Mounting bracket	<ul style="list-style-type: none"> ■ Applicable for ACO ShowerDrain C 	2091164
	Multifit Straight Connector	<ul style="list-style-type: none"> ■ Applicable for ACO ShowerDrain C 	91092
	90 Deg Bend Multifit	<ul style="list-style-type: none"> ■ Applicable for ACO ShowerDrain C 	91094



ACO ShowerDrain E

Product benefits



- Version for tile and flexible sheet flooring
- Option horizontal and vertical outlet
- Superior finish due to electro-polished channels and gratings
- Flexible for any installation situation
- Horizontal gully body can be rotated through 360°



Product information

- Channel body: Stainless steel, material grade 304
- Gully body: Plastic
- Load class: K3
- Internal channel width: 80mm
- Flow rate:
 - 0.4l/s (with 20mm build-up as per EN 1253-1)
- Outlet socket: Suitable for all push-fit pipe socket systems
- Socket version: ND 40/ND 50
- Foul air trap: One-piece with removeable submersible pipe
- Flange design: Factory assembled flange and sealing
- Flange types: Surrounding
- Channel: Electro-polished surface
- Mounting: Modular assembly system consisting of channel body, screwed gully body and design grating
- Grating variants: stainless steel, tileable
- Supplementary components: ACO ShowerStep and hair strainer
- Mechanical clamping system for ultimate reliability for flexible sheet flooring
- Installation height 150-156mm for flexible sheet or tiled floor channel



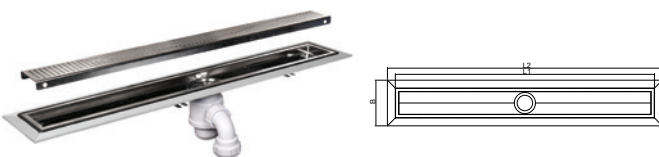

Order data, channel body tiled flooring

Product	Dimensioned drawing	Dimensions			Part no.
		L1 [mm]	L2 [mm]	B [mm]	
Surrounding flange (frame height 15 mm)					
		700	760	146	04435
		800	860	146	04436
		900	960	146	04460
		1000	1060	146	04441
		1200	1260	146	04448





Order data, channel body flexible sheet flooring

Product	Dimensioned drawing	Dimensions			Part no.
		L1 [mm]	L2 [mm]	B [mm]	
Surrounding flange (frame height 15 mm)					
		700	760	170	105781
		800	860	170	105782
		900	960	170	105783
		1000	1060	170	105784
		1200	1260	170	105785

Order data, design gratings tile channel

Products	Design	Part no.				
		700mm	800mm	900mm	1000mm	1200mm
	Wave	04449	04467	04461	04442	04550
	Quadrato	04437	04438	04471	04445	04455
	Intercept	105636	105637	105638	105639	105640
	Tile	105630	105631	105632	105633	105634

Order data, design gratings flexible sheet flooring channel

Products	Design	Part no.				
		700mm	800mm	900mm	1000mm	1200mm
	Quadrato	105786	105790	105794	105798	105802
	Quadrato slip resistant	105787	105791	105795	105799	105803
	Intercept	105788	105792	105796	105800	105804
	Intercept slip resistant	105789	105793	105797	105801	105805

ACO Modular 125

Product benefits

- Ideal project solution for any shower required over 1.2m long
- Flexible lengths available for any shower installation situation
- V-bottomed design for efficient performance at low flow rates
- Self levelling feet for easy installation
- Highly corrosion resistant and durable

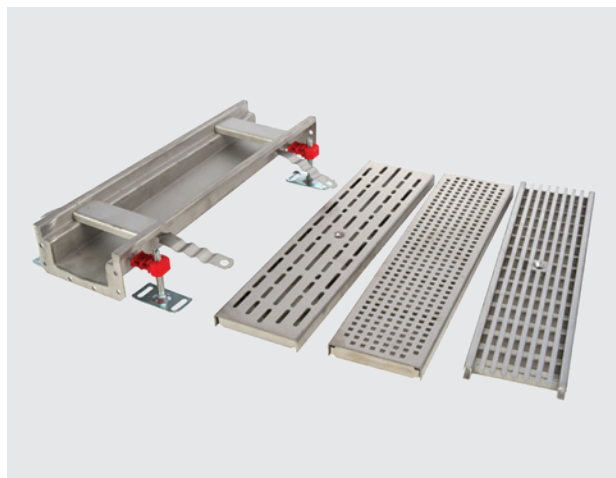

Product information

- Material:
 - Channel body: stainless steel 304 or 316
- Load class: A15 to C250 available
- Internal channel width: 125mm
- The ACO Modular 125+ channel drainage system tested in accordance with BS EN 14331 and complimentary gully systems to BS EN 1253
- Channel lengths 0.5m, 1m, 2m & 3m
- Outlet: Suitable for all push-fit pipe outlet systems
- Outlet version: DN100
- Foul air trap: Selection of foul air traps available based on chosen channel configuration for your project
- Channel: Pickle passivated surface for enhanced corrosion resistance
- Mounting: Modular assembly system consisting of channel body, gully body and design grating
- Scope of delivery channel: Fixing material, height adjustable feet
- Installation height UFL: 30-140mm
- Channels within our Modular 125 range have an adjustment range between 25-50mm above their overall depth



ACO ShowerDrain B

Product benefits

- Minimum building height: 77mm, unfinished floor level
- Smooth surface for optimal cleaning
- Full access to pipeline for optimum cleaning
- Stainless steel channel with screwed plastic gully, no risk of leakage
- 2 in 1 spigot with ND 40 and ND 50

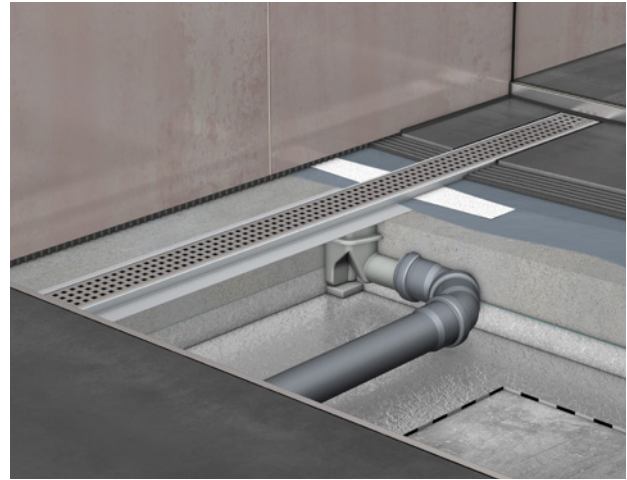

Product information

- Material:
 - Channel body: Stainless steel
 - Gully body: Plastic
- Load class: K3
- Internal channel width: 64mm
- Flow rate:
 - 0.4l/s (with 10mm build-up)
 - 0.5l/s (with 20mm build-up as per EN 1253-1)
- Outlet: Suitable for all push-fit pipe outlet systems
- Outlet version: ND 40/50
- Foul air trap: 1-piece with removable submersible pipe
- Flange design: Permanently cast-on, for optimum connection of a compound seal
- Type of flange: Surrounding
- Mounting: Ready for installation
- Total installation height: 89mm (with water seal 50mm)
- Channel: Pickle passivated
- Grating: Linished
- Grating variant: Stainless Steel design Slot included in scope of delivery
- Product supplied with horizontal gully outlet (vertical outlet available as an accessory see page 29)

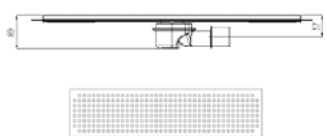

Order data, shower channels with grating and plastic gullies

Product	Dimensioned drawing	Dimensions			Part no.
		L1 [mm]	L2 [mm]	B [mm]	
Installation height UFL: 77 mm (frame height: 12 mm)					
		685	745	130	3015005
		785	845	130	3014042
		885	945	130	3014043
		985	1045	130	3014044

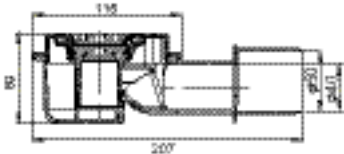
Spare parts

Product	Dimensioned drawing	Description	Part no.
		<ul style="list-style-type: none"> ■ Water seal: 50mm ■ Flow rate: 0.5 l/s (with 20mm water built-up) ■ Installation height UFL: 97mm ■ ND 40/50 	2025386

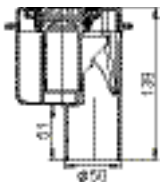
Order data, accessories

Product	Designation	Description	Part no.
		<ul style="list-style-type: none"> ■ Water seal: 50mm ■ Flow rate: 0.5 l/s (with 20mm water built-up) ■ ND 50 	2025389
	Hair strainer	<ul style="list-style-type: none"> ■ Made from plastic ■ For retrofitting 	2026966



Product overview

Point drainage



ACO Stainless Steel Gully systems

32



ACO sanitary gullies Passino

36

ACO Shower Gully System for flexible sheet flooring

Product benefits

- Complete system
- Fulfills the requirements of EN 1253-1
- Vertical gully system fixed height outlet ND 50 and telescopic outlet ND110
- Bonding flange for connecting flexible sheet materials
- Option for round electropolished grate or structured surface for improved slip resistance

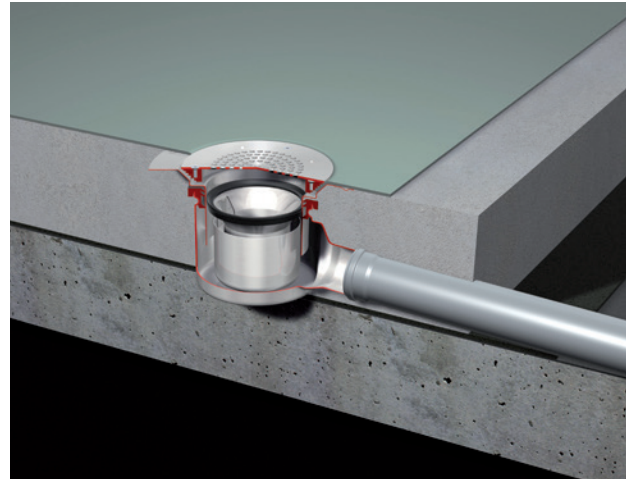

Product information

- Material: stainless steel (gully, gully top and grating) clamping ring plastic
- Load class: K3
- Flow rate:
 - 1.2 l/s (with 20 mm build-up as per EN 1253-1)
- Foul air trap with rubber seal ring
- Suitable for flexible sheet thickness max. 3mm
- Mounting: Ready for installation
- Flexible sheet clamping, plus extended flange for bonding sheet material dia. 225mm
- Outlet: Suitable for all push-fit pipe outlet systems

Order data, gully body



32

Product	Dimensioned drawing	Description	Part no.
		<ul style="list-style-type: none"> ■ Horizontal outlet ND 50 ■ Flow rate: 1.2 l/s ■ Water seal: 50mm ■ Installation height: 118mm ■ Weight: 2.3kg 	405819**
		<ul style="list-style-type: none"> ■ Horizontal outlet ND 50 ■ Flow rate: 1.2 l/s ■ Water seal: 50mm ■ Installation height: 185mm ■ Weight: 2.3kg 	405815**
		<ul style="list-style-type: none"> ■ Telescopic gully ■ Vertical outlet ND 110 ■ Flow rate: 1.2 l/s ■ Water seal: 50mm ■ Installation height: 219-249mm ■ Weight: 1.7kg 	405855*



* 32/40 mm back inlet gully body options available on request

** Supplied with 50 mm connector and 50 to 40 mm reducer

Order data, grate

Product	Description	Suitable for	Part no.
	<ul style="list-style-type: none"> ■ Perforated circular grate □ Stainless steel 304 □ Dia 157mm □ Electropolished 	<ul style="list-style-type: none"> ■ Suitable for round gully top 149 x 149mm Top dia. 225mm 	401185
	<ul style="list-style-type: none"> ■ Slip resistant perforated circular grate □ Stainless steel 304 □ Dia 157mm □ Slip resistant textured finish 	<ul style="list-style-type: none"> ■ Suitable for round gully Top dia 225mm 	104048

Gully kits

Product	Description	Weight	Part no.
	<ul style="list-style-type: none"> ■ 50mm FXD horizontal outlet gully with perforated grate and multifit connector, reducer and 90° bend – vinyl applications 	<ul style="list-style-type: none"> ■ 1.9kg 	402593
	<ul style="list-style-type: none"> ■ 50mm ADJ horizontal outlet gully with perforated grate and multifit connector, reducer and 90° bend – tiled applications 	<ul style="list-style-type: none"> ■ 2.8kg 	402595

ACO Shower Gully System for tiled floors

Product benefits

- Complete system
- Fulfills the requirements of EN 1253-1
- Gully system with 110mm outlet
- Flange for connecting the composite seal
 - 50mm
 - rough surface
- Optimum pipe cleaning access









Product information

- Material: Plastic (gully), stainless steel (frame and grating)
- Load class: K3
- Flow rate:
 - 0.4 l/s (with 10 mm build-up)
 - 0.46 l/s (with 20 mm build-up as per EN 1253-1)
- Foul air trap: One-piece with removable submersible pipe
 - Suitable for: Tile thickness min. 6 mm
 - Mounting: Ready for installation
 - Flange: With surrounding sealing flange 50 mm
 - Outlet: Suitable for all push-fit pipe outlet systems

Order data, gully body

Product	Dimensioned drawing	Description	Part no.
		<ul style="list-style-type: none"> ■ Bonding flange, dia 250mm ■ Water seal: 50mm ■ Installation height: 212-242mm ■ Vertical outlet ND 100 	405854
		<ul style="list-style-type: none"> ■ Clamp flange, dia 225mm ■ Water seal: 50mm ■ Installation height: 130-145mm ■ Horizontal outlet ND 50 <ul style="list-style-type: none"> □ Stainless steel 304 □ Integrated Foul Air Trap 	405821
		<ul style="list-style-type: none"> ■ Clamp flange, dia 225mm ■ Water seal: 50mm ■ Installation height: 130-145mm ■ Horizontal outlet ND 50 <ul style="list-style-type: none"> □ Stainless steel 304 □ Integrated Foul Air Trap 	405817

Order data, grate

Product	Grate style	Material/finish	Load class BS EN 1253	Part no.
	<ul style="list-style-type: none"> ■ Quadrato grate □ 135 x 135mm 	<ul style="list-style-type: none"> ■ Stainless steel 304 □ Electropolished 	<ul style="list-style-type: none"> ■ K3 	104039
	<ul style="list-style-type: none"> ■ Wave grate □ 135 x 135mm 	<ul style="list-style-type: none"> ■ Stainless steel 304 □ Electropolished 	<ul style="list-style-type: none"> ■ K3 	104040
	<ul style="list-style-type: none"> ■ Mondo grate □ 135 x 135mm 	<ul style="list-style-type: none"> ■ Stainless steel 304 □ Electropolished 	<ul style="list-style-type: none"> ■ K3 	104041
	<ul style="list-style-type: none"> ■ Wellness grate □ 135 x 135mm 	<ul style="list-style-type: none"> ■ Stainless steel 304 □ Electropolished 	<ul style="list-style-type: none"> ■ K3 	104043
	<ul style="list-style-type: none"> ■ Classic grate □ 135 x 135mm 	<ul style="list-style-type: none"> ■ Stainless steel 304 □ Electropolished 	<ul style="list-style-type: none"> ■ K3 	104044
	<ul style="list-style-type: none"> ■ Arco grate □ 135 x 135mm 	<ul style="list-style-type: none"> ■ Stainless steel 304 □ Electropolished 	<ul style="list-style-type: none"> ■ K3 	104045
	<ul style="list-style-type: none"> ■ Perforated Square grate □ 135 x 135mm 	<ul style="list-style-type: none"> ■ Stainless steel 304 □ Electropolished 	<ul style="list-style-type: none"> ■ K3 	401183

Order data, slip resistant grate

	<ul style="list-style-type: none"> ■ Slip resistant perforated square □ Stainless steel □ Dia 135 x 135mm 	<ul style="list-style-type: none"> ■ Stainless steel 304 □ Slip resistant 	<ul style="list-style-type: none"> ■ K3 	104047
---	--	---	--	--------

Order data, accessories

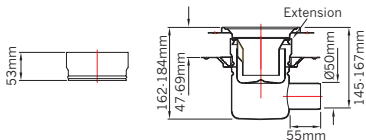
Product	Dimensioned drawing	Description	Part no.
			402725

ACO sanitary gullies Passino

Product benefits

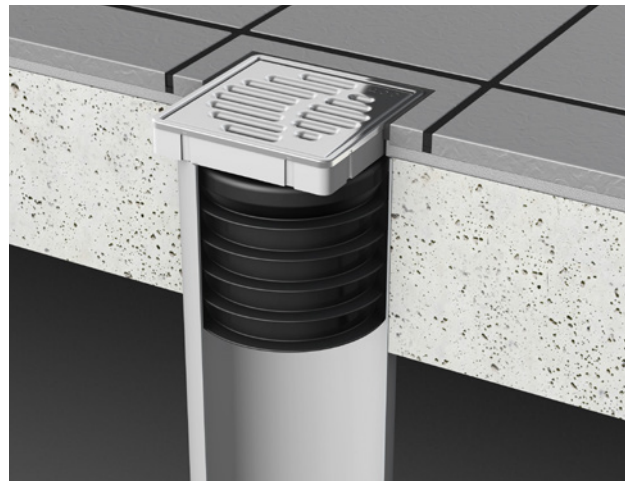

- Refurbishment
- Compact complete system
- Fits to pipe without socket
- Optional flange for the composite seal
 - 50mm
 - rough surface
- fast and easy installation



Product information

- Material:
 - Plastic (gully)
 - Stainless steel (frame and grating)
- Load Class: K3
- Outlet version: ND 100/ ND 125
- Flow rate:
 - 0.83l/s (with 20mm build-up as per EN 1253-1)
- Foul air trap: 2-part, removable
- Mounting: Ready for installation

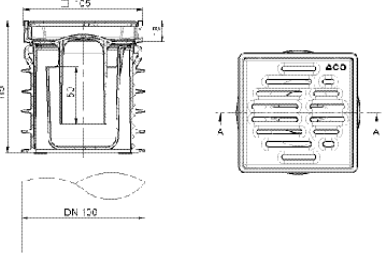
Order data, sanitary gullies Passino

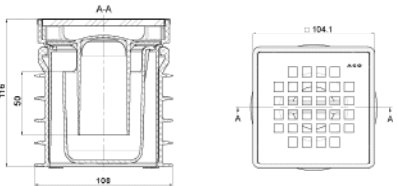
Product	Dimensioned drawing	Description	Part no.
Without flange			
		<ul style="list-style-type: none"> ■ Water seal: 50mm ■ ND 100 ■ Frame <ul style="list-style-type: none"> □ Stainless steel □ 105x105mm ■ Grating <ul style="list-style-type: none"> □ Stainless steel □ 95x95mm □ Load class K3 	2091444
		<ul style="list-style-type: none"> ■ Water seal: 50mm ■ ND 100 ■ Frame <ul style="list-style-type: none"> □ Stainless steel □ 105x105mm ■ Grating <ul style="list-style-type: none"> □ Stainless steel □ 95x95mm □ Load class L15 	2091445

Order data, sanitary gullies Passino

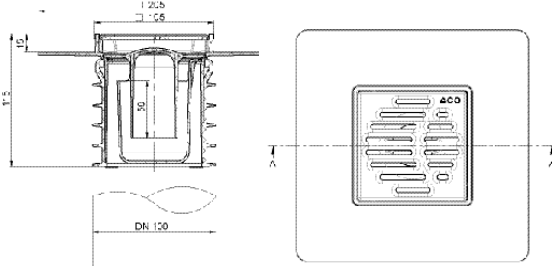
Product	Dimensioned drawing	Description	Part no.
With surrounding flange			
		<ul style="list-style-type: none"> ■ Water seal: 50mm ■ ND 100 ■ Frame <ul style="list-style-type: none"> □ Stainless steel □ 105x105mm ■ Grating <ul style="list-style-type: none"> □ Stainless steel □ 95x95mm 	<p>2091446</p>

Order data, accessories

Product	Designation	Description	Part no.
	Foul Air Trap	<ul style="list-style-type: none"> ■ Water seal: 50mm 	2091470
	Frame	<ul style="list-style-type: none"> ■ Stainless steel: 105x105mm 	2091458
	Grating	<ul style="list-style-type: none"> ■ Stainless steel: 95x95mm ■ Load class K3 	2091459
	Grating Quadrato	<ul style="list-style-type: none"> ■ Stainless steel: 95x95mm ■ Load class L15 	2091450



askACO

train | design | support | care



Every product from ACO Building Drainage supports the ACO WaterCycle



-
- [ACO Water Management](#)
[Civils + Infrastructure](#)
[Building + Landscape](#)
 - [ACO Building Drainage](#)
 - [ACO Access](#)
 - [ACO Sport](#)
 - [ACO Wildlife](#)
-

ACO Building Drainage

A division of ACO Technologies plc

ACO Business Centre
Caxton Road
Bedford
Bedfordshire
MK41 0LF

Tel: 01462 810400
Sales: abdcommercial@aco.co.uk
Technical: abdtechnical@aco.co.uk

www.aco.co.uk/aco-building-drainage

ACO. we care for water

