

Section View of StormSed Filter 1200

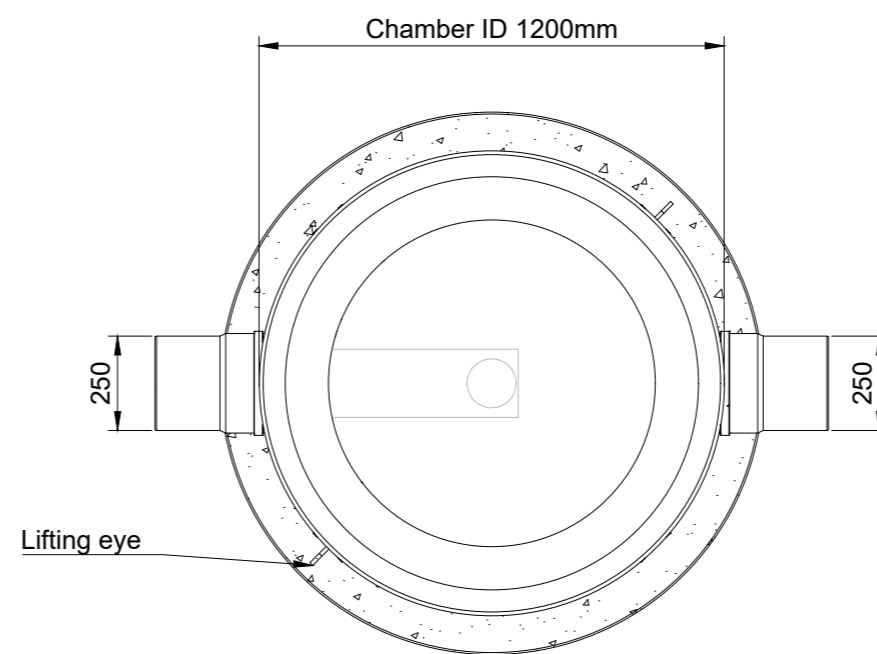
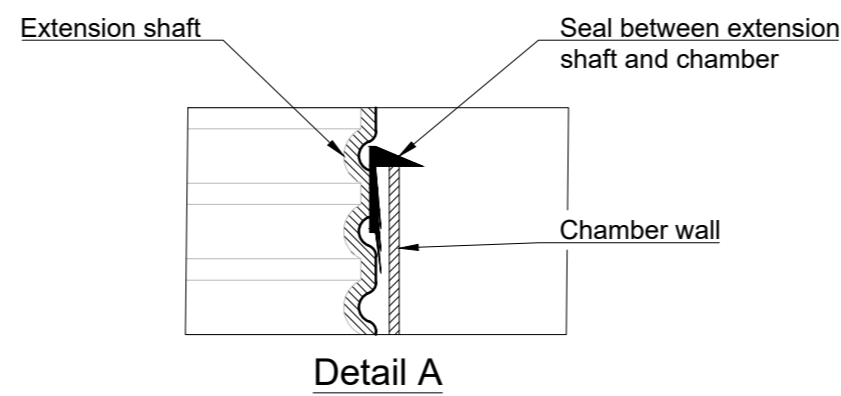

Plan View of StormSed Filter 1200

Notes:

Handling and Storage

- Integral Lifting eyes should be used with spreader bars to avoid deformation of the HDPE walls. DO NOT lift from internal parts.
- Do not sling around inlet/outlet pipes.
- Store on flat, smooth ground, free of sharp objects. Only store vertically. Do not drag, drop or roll the units or extension shafts.

Excavation and Base Preparation

- Concrete surround to suit ground conditions to Engineers detail. Min 150mm bed and surround using C20/25 (to BS EN-206:2013).
- Cast a 150mm thick concrete slab C20/25 in the base of the excavation, ensuring base is flat and level.

Tank Installation Procedure (once base slab has cured to sufficiently support the tank and weight of water, dependant on concrete design)

- Position separator centrally on the base ensuring correct alignment and orientation of inlet and outlet pipes.
- Inlet and Outlet pipes are single wall pipe connections. Flexible pipe connectors should be used to connect to different pipe materials and sizes.
- Fill tank up to invert of pipe connections with clean water during concrete backfill to resist flotation and inward pressure.
- Use concrete surround poured in 750mm initial pour, allowing for 24 hour cure, before proceeding up to required level, ensuring concrete is adequately compacted to prevent formation of the voids.
- Mechanical vibration should be avoided to help avoid excess pressure on chamber walls.

Extension Shafts

- Once the main StormSed unit has been cast in place ensure the extension shaft can be pre fitted and measured for cutting. Extension shaft should then be removed and cut to size from the base of the shaft using appropriate tools. Ensure the cut is level all around.
- Fit extension shaft and ensure seal is in place between chamber and extension shaft where supplied
- Concrete should be adequately compacted to prevent formation of voids.
- Ensure manhole covers are installed as per drawing on reinforced concrete cover slab.
- Ensure loads are not transferred to the tank or shaft extensions

General notes

- Installed tanks should be covered during site works to prevent site waste and rubbish from entering the units.

Best Practice and Workmanship:

- ACO can give guidance with respect to the most suitable methods of installation for each of the products in the ACO StormSed range. Products should be installed using acceptable levels of workmanship according to the National Code of Practice (UK: BS8000-0:2014)
- Detailed installation statements and methodologies will vary for all sites as each will have different aspects deserving particular consideration and the relevant approvals should be sought from the consulting engineer and/or the installer.

| | | | |
|---|-------------------------|---|---------------|
| A | 17/11/2025 | Initial Issue | AM |
| Version | Date | Description | Name |
|  | | Drawing Number: 24210 Title: ACO STORMSED FILTER 1200 INSTALLATION OVERVIEW DRAWING - INSITU CAST CONCRETE | Revision: A |
| Created by: IM | Released by: RB | Projection: ISO-A | Units: mm |
| Created at: 11/6/2025 | Released at: 17/11/2025 | Format: A2 | Scale: 1 : 20 |
| Replacement for: | Replaced by: | Information contained in this drawing is copyright property of ACO Technologies plc. Any reproduction in part or whole without written permission of ACO Technologies plc is prohibited | |
| | | | Sheet: 1 of 1 |